



Spray Nozzles & Systems for Pharmaceutical Industry





A World Class Indian Spray Nozzle Manufacturer

Spraytech Systems (India) Pvt. Ltd. was started by Shri. Bapusaheb Kharade, in early 2000 as a Spray Nozzle Manufacturer for replacement market catering to Steel Industries. Primarily company was started in a 1000 sq. feet workshop & within a decade it is elaborated to 7000 sq. feet modern factory. An another factory is started at Indapur 100 kms. away from Pune with a area of 2,00,000 sq. feet is again a big achievement for the Organisation. Recently Spraytech has started one another factory at Rabale (Navi Mumbai) with area of 13000 sq. feet. All three factories are facilitated with next generation class CNC machines, heavy material handling equipments to serve raising market demands with no compromise with world class product quality. Along with this field of engineering we are entered in forging to serve respective product demands.

"Spraytech" is a leading organisation & a good name in the market for mfg. of Spray Nozzles.

We attribute our success to our motivated and skilled work force who can accomplish job orders of varying magnitudes and complexities. We are proud to have esteemed customers who have entrusted their faith in us over the years.

The aim of our organization is customer satisfaction which is achieved through following objectives: Commitment to quality, Prompt response, Technological solutions, On time delivery, After sales service.

Our challenge is to meet the widely ranging delivery demands of an equally diverse customer base coupled with constant upgradation of production equipment and techniques to keep pace with new market trends and applications.



Index

Spray Nozzle Selection Guide	3
Literature	5
Tablet Coating Spray Nozzles	9
Mounting Assembly & Accessories for Coating Spray Nozzles	13
FBP Top Spray Nozzles & Lances	14
FBP Bottom Spray Nozzles & Lances (Wurster coating)	15
RMG / HSG Spray Nozzles & Lances	16
Air Atomizing Spray Nozzles	18
Cleaning-In-Place (CIP) Spray Nozzles	25
Flat Spray, Full Cone, Hollow Cone Spray Nozzles	35
Air Conveyor	47
Spray Coverage Table	48
Units Conversion Data	49
Registered Trademark Ownership	49
Enquiry Formats	50

Manufacturing & Testing Facilities

Test Rig - 1



Test Rig - 1

A) Testing Capacity : 200 M³/Hr
Total Pressure Drop : 2 Bar
B) Testing capacity : 43 M³/Hr
Total Pressure Drop : 7 Bar

Test Rig - 2



Test Rig - 2

A) Testing capacity : 1-350 LPM
Total Pressure Drop : 10 Bar
B) Testing capacity : 1-260 LPM
Total Pressure Drop : 9 Bar



Spray Nozzle Selection Guide By Application & Spray Pattern

Category of Nozzles	Applications	Spray Patterns
FLAT SPRAY	Rinsing, High Pressure Cleaning, Granulation, Coating	
FULL CONE	Surface Spraying, Coating Washing & Cooling of flue gases, Scrubbing	
MIST SPRAY NOZZLE	LDO firing in boiler & Dust suppression	
HOLLOW CONE	Fugitive dust suppression, Scrubbing essentially small droplet size, Coating	
OIL BURNER SPRAY NOZZLE	LDO firing in kilns of cement, sponge, Iron plants & Dust suppression	
TANK WASHING	Cleaning of inside surface of barrels & tanks. CIP	
FINE ATOMIZING NOZZLE	Gas cooling, conditioning or humidifying applications, for improving the chemical reaction by increased contact surface	
AIR ATOMIZING NOZZLE	Coating, Atomizing of viscous liquids, Gas cooling, conditioning or humidifying, Chemical process engineering. Pan coating, Tablet coating FBD Granulation	

Droplet Size Selection

Single Fluid Spray nozzles	Liquid Pressure [barg]					
	1		2		3	
	Flowrate V [l/min]	Droplet size [µm]	Flowrate V [l/min]	Droplet size [µm]	Flowrate V [l/min]	Droplet size [µm]
Inline Entry Hollow Cone Spray Nozzle	0.10 0.5	110 210	0.10 1.50	130 230	0.17 1.60	110 190
Tangential Entry Hollow Cone Spray Nozzle	0.10 1.80	290 690	1.00 25	330 650	1.60 40	230 480
Full Cone Spray Nozzle	0.70 18	550 1310	1.00 25	390 1090	1.60 40	310 760
Multi-Tip Spray Nozzle	0.90 20	190 390	1.25 28	185 275	2.00 44	140 180
Flat Spray Nozzle	0.70 18	410 1210	1.00 25	350 990	1.60 4.00	310 700

Air Atomizing Spray nozzles	Air / Water [Nm ³ /h:l/min]					
	1		2		3	
	Flowrate V [l/min]	Droplet size [µm]	Flowrate V [l/min]	Droplet size [µm]	Flowrate V [l/min]	Droplet size [µm]
External / Internal Mixed	As Per Ratio	95	As Per Ratio	95	As Per Ratio	95

Quality Policy

We at SPRAYTECH SYSTEMS INDIA PVT. LTD. are committed to achieve total Customer satisfaction through Design, Development, Manufacturing and Supply of consistent quality Industrial Spray Nozzles & Systems with aim of zero percentage rejection at customer's end while remaining cost effective and competitive. This shall be achieved through team work and continual improvement in all our areas of operation.

Vision

We are putting all our efforts to improve efficiency of our products with effective cost cutting. We are all committed to on time delivery, quality products, prompt after sales service and product technical support.

Mission

We provide hygienic working environment with all necessary facilities for better working environment. We encourage to safety measures to avoid troubles to workers and processes. Our customer is our first priority and we always try to serve best to our customer.

Spray Characteristics

Spray nozzles are designed to perform under various spraying conditions. The following characteristics should be used when considering which nozzle to select.

- Spray Pattern
- Flow Rate & Pressure
- Spray Angle
- Droplet Size
- Material Selection

Spray Pattern

Spray nozzles selection follows primarily from its application. Spray nozzles are designed to perform under many different spraying conditions. Selecting a spray based on the pattern and other spray characteristics needed generally yields good results.

Each spray pattern is described further with applications to assist you in your nozzle selection.

Capacity

Nozzle capacity (flow rate) varies with spraying pressure. It also depends on the specific gravity of the liquid. Thus, for lower specific gravity, the flow rate is larger than for liquid with a higher specific gravity at the same pressure.

Spray Angle

Spray angle varies with the distance from where it is going to spray. Liquids with more viscosity gives narrow spray angle and vice-versa.

Droplet Size

In many applications like physical or chemical processes, which involve sprays, greatly depend on droplet size distribution. Significant factor influencing droplet size include nozzle type, capacity, spraying pressure and spray pattern.

Material Selection

Following types of materials are generally used.

- 1 Stainless steel (SS 304, SS 316, SS 316 L & all grades)
- 2 Hardened SS
- 3 Hastelloy B[®]
- 4 Hastelloy C[®]
- 5 Plastic Material
 - PVDF
 - PTFE (Teflon)[®]
 - PEEK

** Special Material and Connection on request

Literature

Tablet Coating Process

It is the process to apply coating material on external surface of tablets to enhance its efficiency and properties.

Today many solid pharmaceutical dosage mediums are produced with coatings, either on the external surface of tablets, or on materials dispensed within gelatine capsules.

Coating serves a number of purposes right from protecting stomach lining from aggressive drugs to protecting the tablet from stomach acids. It also helps in maintaining the shape of the tablet and thus can offer a delayed release of the medication.

But for good results, a better coating medium is required. And the same can be fulfilled by Tablet coating spray nozzles.

General purposes of tablet coating

- Covers unpleasant taste, colour and odour
- Chemical and physical protection from environment
- To control the release of drug with enteric coating
- It protects drug from gastric surrounding of stomach
- Provide way to identify the drug and improves appearance

Results of bad coating

- Sticking or picking
- Roughness
- Twinning
- Peeling
- Cracking

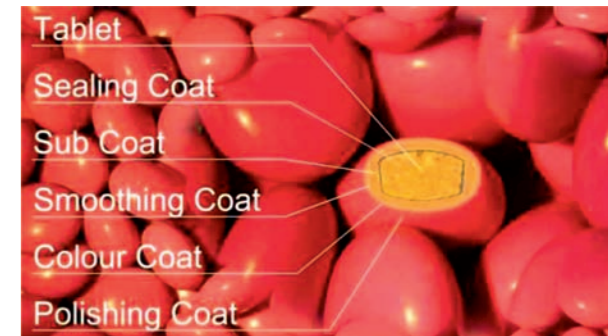

Example of Bad Tablet Coating

Granulation With RMG / HSG

Also known as wet granulation process. material is loaded into bowl having agitator and chopper and mixed rigorously then binder material is sprayed from top and granules are formed.

Good quality granules are foundation for good quality tablet.

Various liquid blenders are used for wet granulation.

Spraying binder over bulk material could reduce wet granulation cycle time and increase productivity.



Fluid-bed System

Fluid bed process consists of following applications :

- 1. Drying**
Process of extracting moisture from solid bulk material by making it fluidized with high flow blow of air, so moisture is removed homogeneously and all over surface of every single particle.
- 2. Granulation / Agglomeration**
Powder particles of bulk material bonded by liquid fine spray. Liquid could be water or an organic solvent and the powder material will be mixed together. Agglomerate has less strength of particle bond.
- 3. Coating**
Fluidized particles are coated with spray of coating material which enhances. coating film must be very uniform over the particle surface.
- 4. Tangential Coating**
Centrifugal motion is used for making spherical pellets, at the same time particles are bonded by binder liquid. layering also can be done in same way.

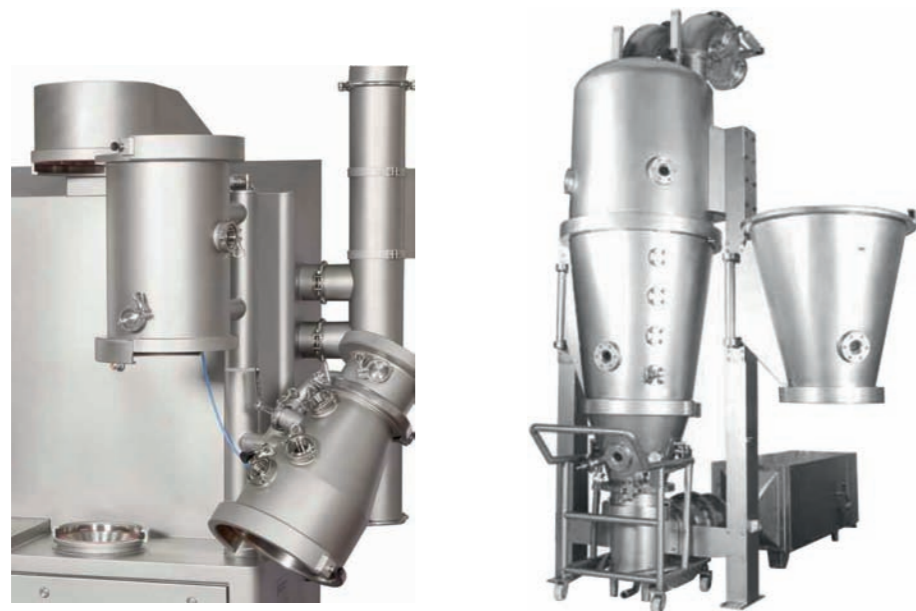
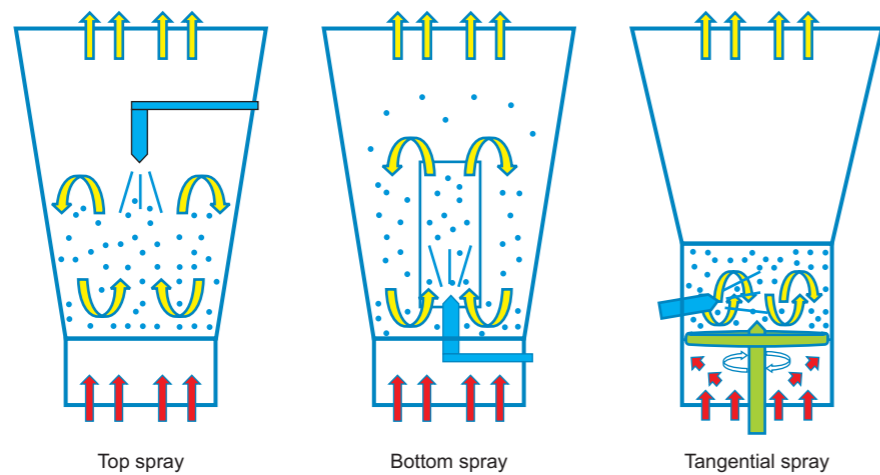

Application

Tablet Coating
Atomization of viscous liquids
Granulation
Pellet Coating
Agglomeration
Humidification of air

Air Atomizing Spray Nozzles

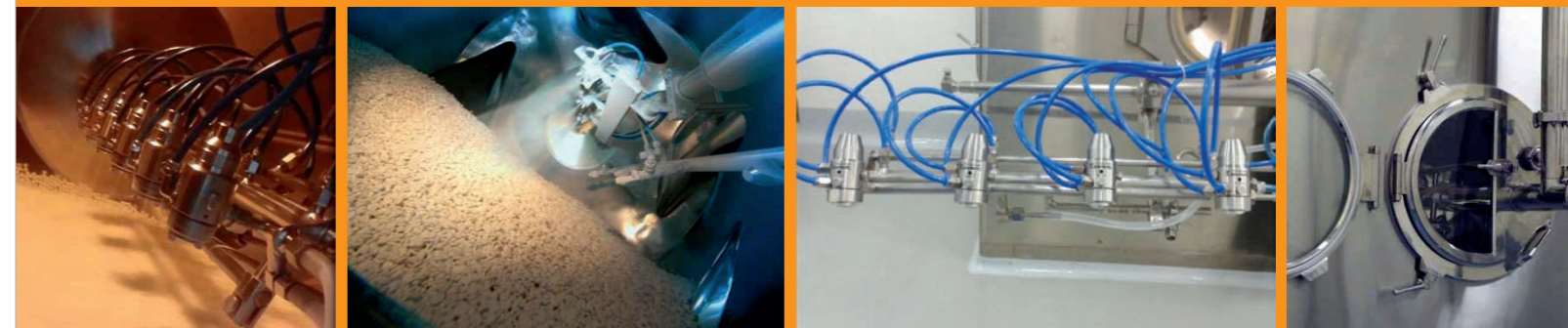

Spraytech Product Coding For TABLET COATING SPRAY NOZZLES

The following description will help to explain our Part Number/ Code in relation to the "SPRAYTECH" Spray Nozzle
EXAMPLE ORDERING.

SPRAYTECH	RA	10	M2L	XA
↓ Company Name	↓ Spray Nozzle Series	↓ Orifice Size	↓ Material Code	↓ Thread Type
	↓ Sub-type of Nozzles			↓ Thread Size

1) Spray Nozzles Series

R = Coating Nozzle

2) Sub Type of Nozzles

CS



B



C



3) Orifice Size

05 = 0.5mm
08 = 0.8mm
10 = 1.0mm
12 = 1.2mm
15 = 1.5mm
18 = 1.8mm
20 = 2.0mm

4) Material code

M2 = SS316
M2L = SS316L

5) Thread Type Code

X = BSPP
Note : Special Connection on request

6) Thread Size code

A = 1/8" B = 1/4"
C = 3/8"
Note : Special Size on request

P1 = PVC (Polyvinylchloride)
P2 = PP (Polypropylene)
P3 = Teflon®/PTFE (Polyterafluoroethylene)
P4 = Nylon (Polyamide)
P5 = Delrin®/POM (Polyacetate)
P6 = PVDF (Polyvinylidene fluoride)
P7 = Polyethylene

Tablet Coating Spray Nozzles RC SERIES



Spraytech's RC Series tablet coating spray nozzle are specially designed to meet GMP requirements where surface texture plays very important role.

The unique Air Cap design makes it Anti Bearding and keeps coating process shutdown free, thus higher production ratio and quality requirements are achieved.

RC series spray nozzle is a compact device incorporating of independent controls for Liquid, Atomizing Air and Fan Air for fine tuning of spray capacity, droplet size and spray patterns. It is available in wide variety of spray setups that give a complete selection of flow rate and flat spray patterns.

R series spray nozzles are externally mix nozzles. This means the liquid and air are mixed outside of air cap to produce complete atomized spray.

The liquid atomization is controlled by varying atomizing air and fan air pressures without changing liquid flow rates. The flat spray pattern is controlled by varying the fan air pressure in conjunction with the atomizing air. This is effective for high viscosity liquids, coatings and suspensions.

Tablet coating spray nozzle features a cylinder for controlled "on-off" operation. The cylinder controls a liquid clean-out/ Shut-off needle which also cleans the liquid orifice.

Spray Nozzle	Type	RC
Spray Type :	Airborne	Air Atomised
Liquid orifice size Range (standard)	mm	0.8 - 1.5, (1.0)
Solution Flow Rate (typical per nozzle)	Liters/hour	6 - 30
Atomizing Air Pressure Range	bar	0.7 - 3
Spray Width Pressure Range	bar	1.0 - 4.0
Maximum Compressed Air Pressure	bar	5.5
Compressed Air Consumption (maximum @ 2.0 bar)	Nm ³ /hour	10.5
Seal Material (standard) check compatibility for organic use	FDA	Approved

DESIGN FEATURES

1. Separate atomizing and fan air lines for complete control.
2. Provides variable coverage and fine control of drop size without affecting liquid flow rates.
3. Higher atomizing air pressure yields fine droplet size.
4. Higher fan air pressure yields broader patterns.
5. Non clogging and anti - bearding design

The R Series coating Spray Nozzle are a compact, precision nozzles. Incorporating independent controls of liquid atomizing air and fan air for fine tuning of spray capacity droplet size and spray patterns. It is available in a wide variety of spray Set-ups that give a complete selection of flow rates and flat spray patterns.

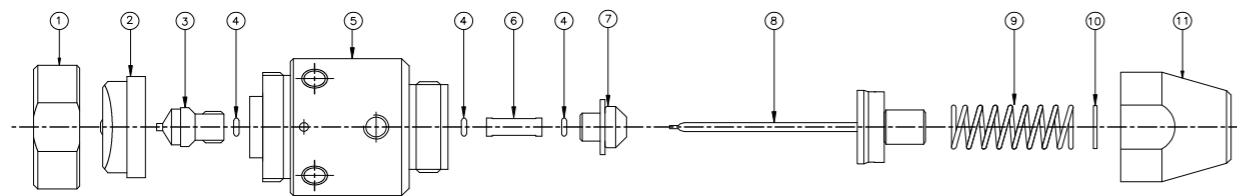
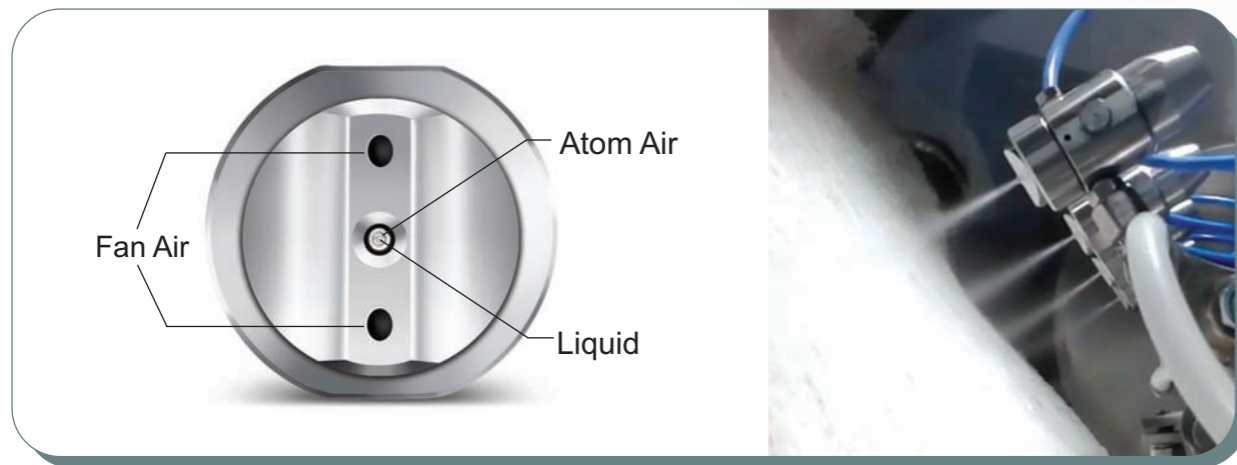

Part Details

- | | |
|-------------|--------------------|
| 1 Lock Nut | 7 Cup Seal Packing |
| 2 Air Cap | 8 Needle Assembly |
| 3 Fluid Cap | 9 Spring |
| 4 Seal | 10 Strainer Disc |
| 5 Body | 11 End Cap |
| 6 Spacer | |

Details of Inlet Connections

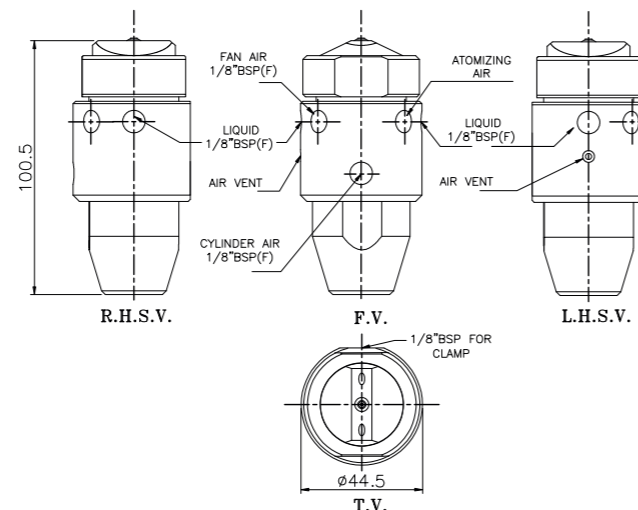

RB Series Flat External Mix Coating Spray Nozzles

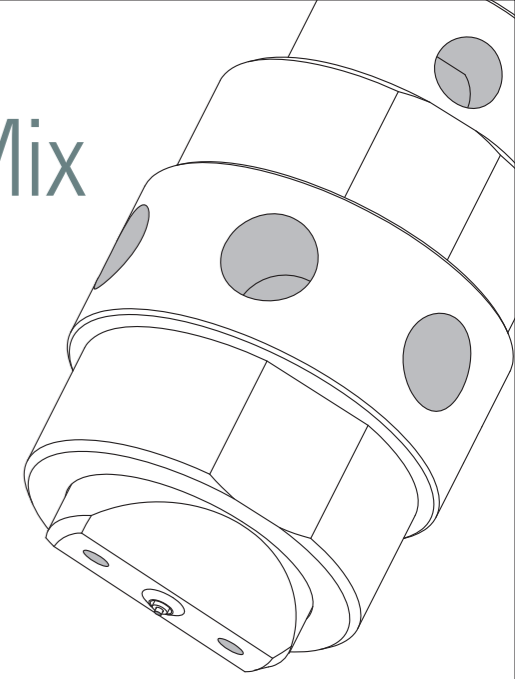

Design Summary :

- RB Series variable spray nozzles provide uniform spray distribution with uniform droplet sizes, even when spraying viscous fluids.
- For finest tuning of liquid flow rate along with spray pattern and droplet sizes independent controls are given in spray nozzles assembly.
- Suitable for large scale production.
- For various settings of spray droplet sizes separate air controller is given in spray nozzle assembly.
- Additional inlet /outlet port allows for liquid re-circulation that effectively maintains the flow of viscous liquids.
- Having removable auto shut off and spring loaded needle cylinder assembly is provided for maintenance.
(Liquid Orifice Range : 1.0 to 2.0 MM)

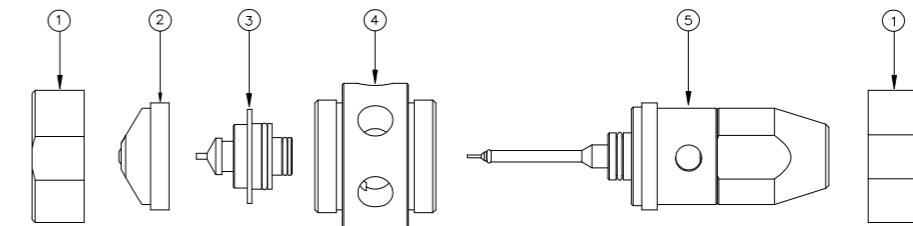

Part Details

- 1 Lock Nut
- 2 Air Cap
- 3 Fluid Cap
- 4 Body
- 5 Cylinder (Needle) Assembly

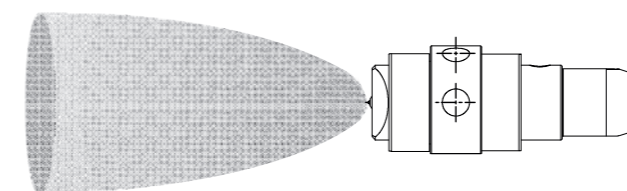

With fan air: Flat Spray Pattern.
Without fan air: Round Spray Pattern.

Details of Inlet Connections :

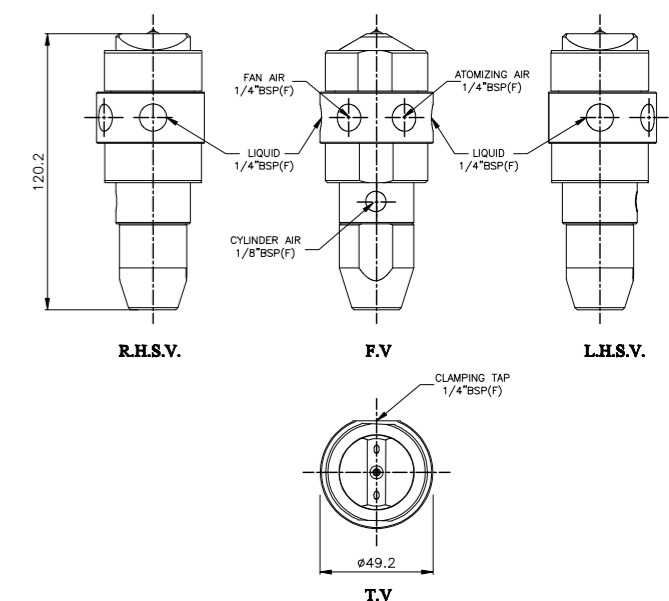

RCS Series Spray Nozzles

With Flow Control



Liquid Orifice Range : 0.5 to 1.2 MM

SPRAYTECH'S Latest Development, RCS series coating spray nozzles offers very compact design with innovative flow control feature. This feature offers the user to take the RCS coating nozzle from the lowest 20 ml to its max limit is just a spin.

RCS type coating spray nozzle is very light weight and features anti bearding air cap design which eliminates the deposition of material over the air cap and abolishes bearding over gun.

RCS comes with individual ports for liquid, Atomizing, Fan control and auto shut-off for total control. Also as it is has external mixed design thus, atomized spray properties could be changed as per need with fine tuning of individual pressures of Atomizing air, Fan Air & Liquid pressure.

Innovative needle assembly provides the Auto-shut off and Auto Cleaning of liquid orifice.

RCS type coating spray nozzle is suitable for Lab-coater, Auto Coater and Conventional coater.

Spray setup available with Flat Fan, and Round Pattern.

All Sealing materials are FDA Approved.

Part Details

- 1 Lock Nut
- 2 Air Cap
- 3 Liquid Nozzle
- 4 Body
- 5 Needle Assembly
- 6 Needle Spring
- 7 End Cap
- 8 Check Nut
- 9 Flow Adjustment Screw

Mounting Assembly

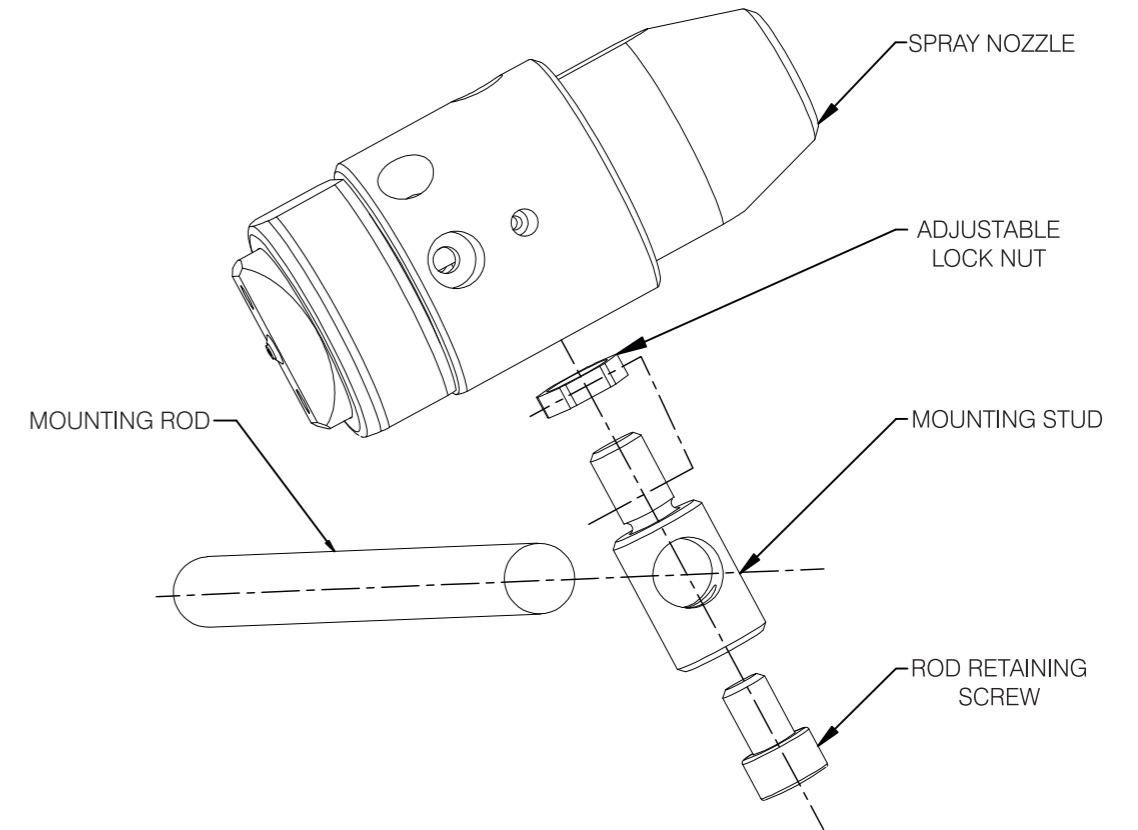

Accessories

Optional Accessories available for R series coating spray nozzles

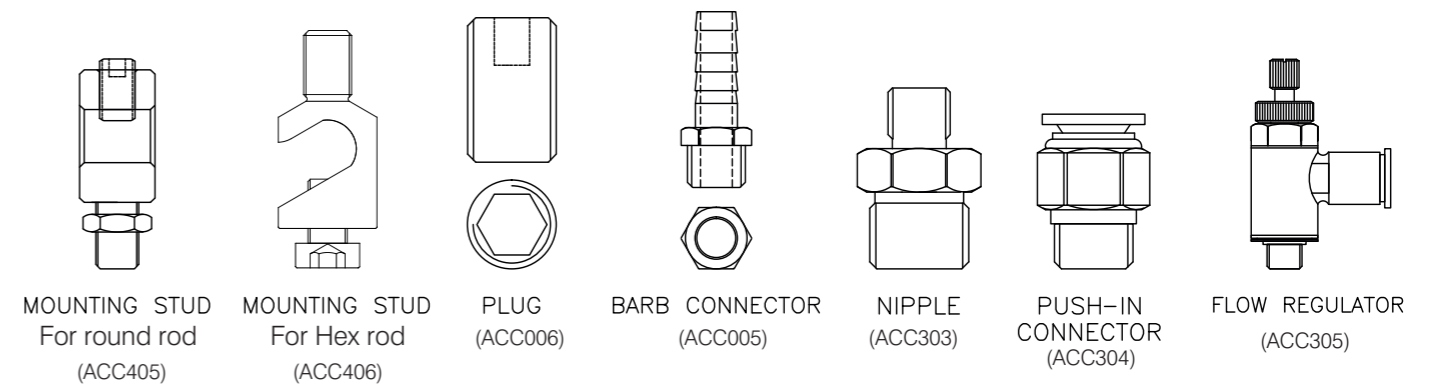

FBP Top Spray Nozzle & Lance

Spraytech's Top Spray Nozzles are design for Large Scale, Medium Scale and Lab Scale Fluid Bed Processors.

Manufactured according to GMP and available in wide range of spray rates. And external mix spray setup enhances the spray quality and distribution in optimum way.

Design Features

- Available in 1, 3, 6, 7 spray heads
- Available in various spray angles (Top down spray)
- Auto-shut off Feature
- Anti-drip spray heads
- Long Life Lance design
- Compact design of spray nozzle
- Homogeneous spray distribution
- Fine droplet size, best for dry granulation, pallet coating, and agglomeration.
- GMP Suitable design
- Anti-clogging lance
- Made from SS316L and All O-rings from FDA Approved material
- Custom made designs available

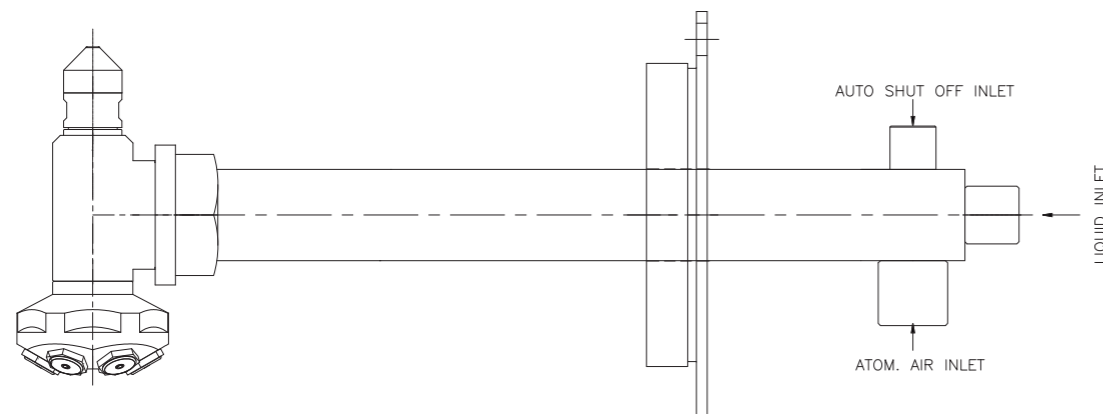
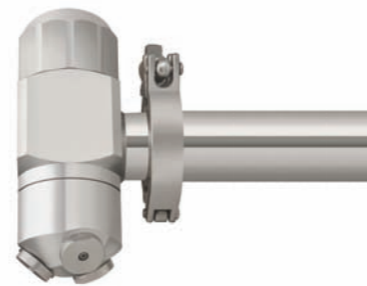
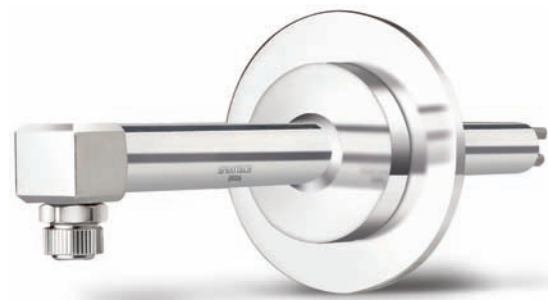

FBP Bottom Spray Nozzle & Lance (Wurster Coating)

Spraytech's specially designed and customizable Fluid bed Bottom spray (Wurster coating) nozzle helps to improve the wurster coating application and also makes it possible to attain high-quality results in coating pellets and particles.

Designed for All type of Bottom Spray Coating, Allegiant spray distribution and fine droplets results in optimum quality of coating. Light weight design and easy to control the spray parameters. Minimum internal parts hence less maintenance,

Design Features

- Optimum spray quality
- Anti-drip spray tip
- Auto-clean needle assembly
- Easy to assemble and dismantle
- Special air cap design to avoid material build-up
- GMP Suitable design
- Anti-clogging lance
- Available with various orifices sizes
- Made from SS316L and All O-rings from FDA Approved material
- Custom made designs available

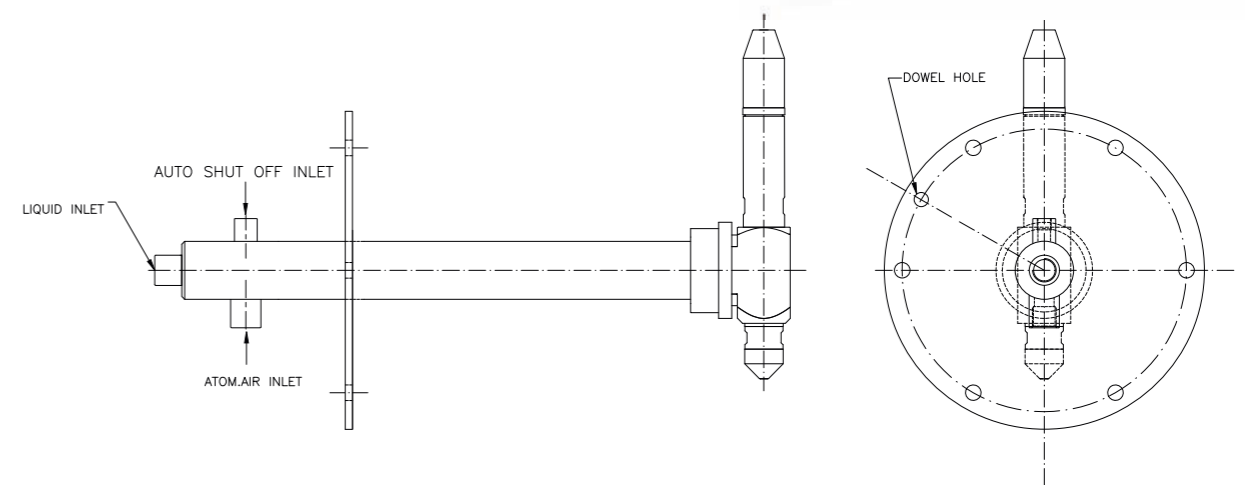

RMG / HSG Top Spray Nozzle & Lance

Spraytech's RMG / HSG Top Spray Nozzles & Lance are design for Large Scale, Medium Scale and Lab Scale Rapid Mixer Granulator and High - Shear Granulator for Wet Granulation. Superior spray quality produces best in class granules from bulk. Manufactured according to GMP and available in wide range of spray rates. And external mixing spray setup enhances the spray quality and distribution in optimum way.

Spray Nozzles and special purpose lance designs available

Design Features

- Available in 1, 3, 4 spray heads
- Available in various spray angles
- Auto-shut off feature
- Anti-drip spray heads
- Long Life Lance design
- Compact design of spray nozzle
- Homogeneous spray distribution
- Fine droplet size, best for wet granulation,
- GMP Suitable design
- Anti-clogging lance design
- Made from SS316L and All O-rings from FDA Approved material
- Custom made designs available



Spray angle range : 60° - 80°

Flow range : 10 LPM to 50 LPM

Features:

- Anti drip Spray setup
- Auto shut off
- Finest droplet Size

Internal Mix Setup



Special Design For R&D & Pilot
RMG / HSG Equipment

Spray angle range: 20° - 90°

Flow range : 1 LPM to 8 LPM

Air Atomizing Design, Features & Introduction

Air atomizing spray nozzles produces fine mist spray with the help of compressed air, liquid breaks into small droplets as air provides shearing effects on liquid droplets. Various spray patterns are available, they are categorized into Flat and Round spray patterns. The droplet size can be adjusted by flow adjustment of compressed air. Air atomizing nozzles are divided into two types Internal and External mix air atomizing nozzles. Those are available in various metals.

An air atomizing spray nozzles can work on three principles as below :

- 1) Pressure Principle
- 2) SIPHON Principle
- 3) Gravity Head Principle



Choice of spray Nozzles

Each spray set-ups consists of an air cap and liquid cap which provide a specific spray pattern capacity and coverage performance

Inside Body Mixing

Liquid and air streams meet within nozzle and are mixed together and expelled through the same orifice. This internal mixing means the streams are not independent; a change in air flow will affect the liquid flow. This makes precise metering of the liquid more difficult than with an External Mix Set-up. Internal Mix set-up are able to produce the finest atomization of any of the XA set-ups, but they are generally not suitable for use with liquids which have a viscosity that is above 200 centipoise.

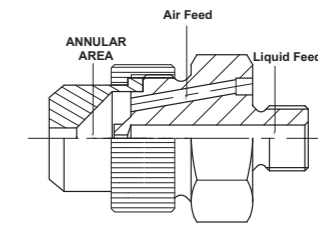

Internal Mix Set-Ups
Air & Liquid mix inside the nozzle

Out Side Body Mixing

The air and liquid streams exit the nozzle independently and are combined and mixed outside of the nozzles. Because there is no connection between the air and liquid lines within the nozzles, the air and liquid flow rates can be controlled independently, allowing precise metering of the liquid. The atomization can be controlled by adjusting the air flow rate more air produces finer atomization. In most cases these set-up do not atomize as finely as Internal Mix Set-ups.

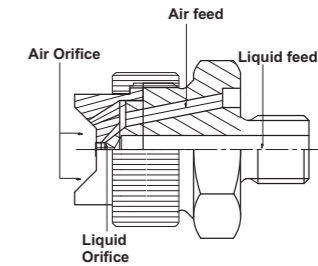

External Mix Set-Ups
Air & Liquid exit independently and combine outside the nozzle

External Mix Set-up may be used with liquid having a viscosity above 200 centipoise and for abrasive suspensions. Spraytech provides Engineering guidance for spraying high viscosity liquids.

Applications

1. Tablet Coating
2. Thin Film Coating
3. Humidification
4. Paper Moisturising
5. Dust Suppression

Optional Features

1. Manual Shut-off / Cleaning Needle
2. Automatic self Cleaning Needle
3. Auto shut-off Arrangement

Material Code

- M1 = SS303/SS304
- M2 = SS316/ M2L = SS316 L
- M3 = Brass (Nickel Plating on Request)
- M4 = SS410/ M4-3=SS310



1) Pressure Principle

Liquid is supplied in pressurised form with the help of pump or pressurised container, separate compressed air is needed

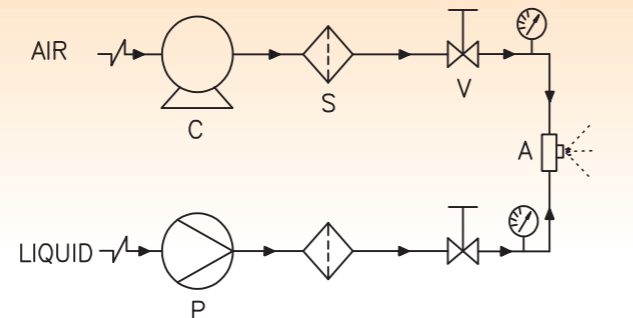

2) Siphon Principle

Siphon principle is utilised to lift liquid from certain height from spray nozzle, suitable where pump or pressurised container of liquid is not available.

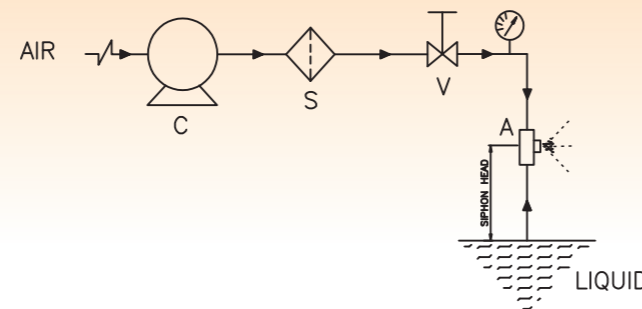

3) Gravity head Principle

Gravitational head of liquid is utilised to feed liquid to the spray nozzle, suitable where pump or pressurised container of liquid is not available.

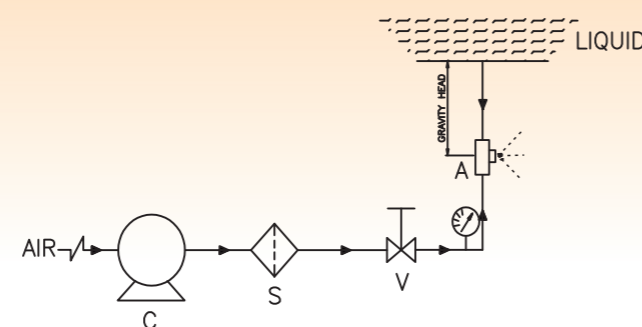

DASA Series Full Cone Siphon Air Atomizing Spray Nozzles

DESIGN / SPRAY CHARACTERISTICS

- Lowest flow available
- Very fine atomization
- Narrow spray angle (Range 12°- 25°)
- Full cone pattern
- Short to moderate forward spray projection

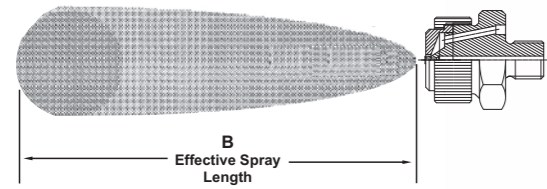

Flow Rates and Dimensions

Siphon-fed / External Mix, Round Spray Pattern, 1/8" and 1/4" Pipe Sizes, BSP or NPT

Pipe Size	Spray Set-up Number	ATOMIZING AIR		Liquid Capacity in l/h (Liters Per Hour)								Spray Dimensions at 200 mm. Siphon Height	
				Gravity Head				Siphon Height					
		Air (bar)	Nm ³ /h	450 mm	300 mm	150 mm	100 mm	200 mm	300 mm	600 mm	900 mm	"B" Effective Spray Length (mm)	Max. Spray Length (m)
1/8 or 1/4	DASA 050	0.7	0.66	1.5	1.3	1.1	0.9	0.7	0.5	0.6	0.8	280	1.8
		1.5	1.02	1.8	1.7	1.5	1.3	1.2	1.1	1.1	0.9	280	1.9
		3.0	1.68	2.1	1.9	1.7	1.5	1.4	1.3	1.3	1.1	300	2.3
		4.0	2.16	2.2	2.0	1.8	1.6	1.5	1.4	1.4	1.2	360	2.6
1/8 or 1/4	DASA 150	0.7	0.78	24	2.1	1.7	1.5	1.2	0.8	0.9	1.1	300	2.1
		1.5	1.20	2.8	2.6	2.4	2.1	1.9	1.6	0.9	1.1	330	2.3
		3.0	1.92	3.4	3.1	2.9	2.8	2.6	2.4	1.7	1.5	380	2.6
		4.0	2.46	3.7	3.4	3.3	3.1	2.9	2.7	2.1	1.5	430	3.0
1/8 or 1/4	DASA 200	0.7	1.38	2.5	2.3	2.0	1.6	1.4	1.1	0.9	1.2	300	2.4
		1.5	2.16	2.9	2.8	2.5	2.2	2.0	1.7	1.9	1.2	330	2.7
		3.0	3.48	3.4	3.3	3.2	2.9	2.8	2.5	2.5	2.0	380	3.4
		4.0	4.44	3.7	3.6	3.5	3.4	3.3	3.0	3.0	2.5	430	4.0
1/8 or 1/4	DASA 250	0.7	1.14	4.5	4.0	3.4	2.1	1.8	1.4	1.8	1.2	380	3.0
		1.5	1.86	5.3	4.9	4.4	3.5	2.9	2.7	2.4	1.2	410	3.4
		3.0	3.00	6.0	5.6	5.0	4.4	4.0	3.4	2.4	1.9	460	4.0
		4.0	3.90	5.7	5.4	5.0	4.2	3.9	3.5	2.8	1.9	510	4.6
1/8 or 1/4	DASA 400	1.5	3.48	22	19.9	16.3	12.3	10.5	8.3	2.8	2.8	460	3.7
		3.0	5.28	25	23	19.5	16.7	14.2	11.5	6.4	4.5	510	4.3
		4.0	6.66	26	24	21	18.4	15.7	12.9	7.9	6.1	530	4.9
		5.6	8.82	26	24	22	19.7	17	14.6	9.8	6.1	580	5.5
1/8 or 1/4	DASA 450	2.0	8.64				27	22	16.8			510	6.7
		3.0	11.4	44	43	40	30	26	21	11.0	8.3	530	7.0
		4.0	14.4		42	39	31	28	23	16.7		580	7.6
		5.6	18.9				31	28	24			630	8.2

Standard Materials: Nickel-plated Brass, 303 Stainless Steel and 316 Stainless Steel.

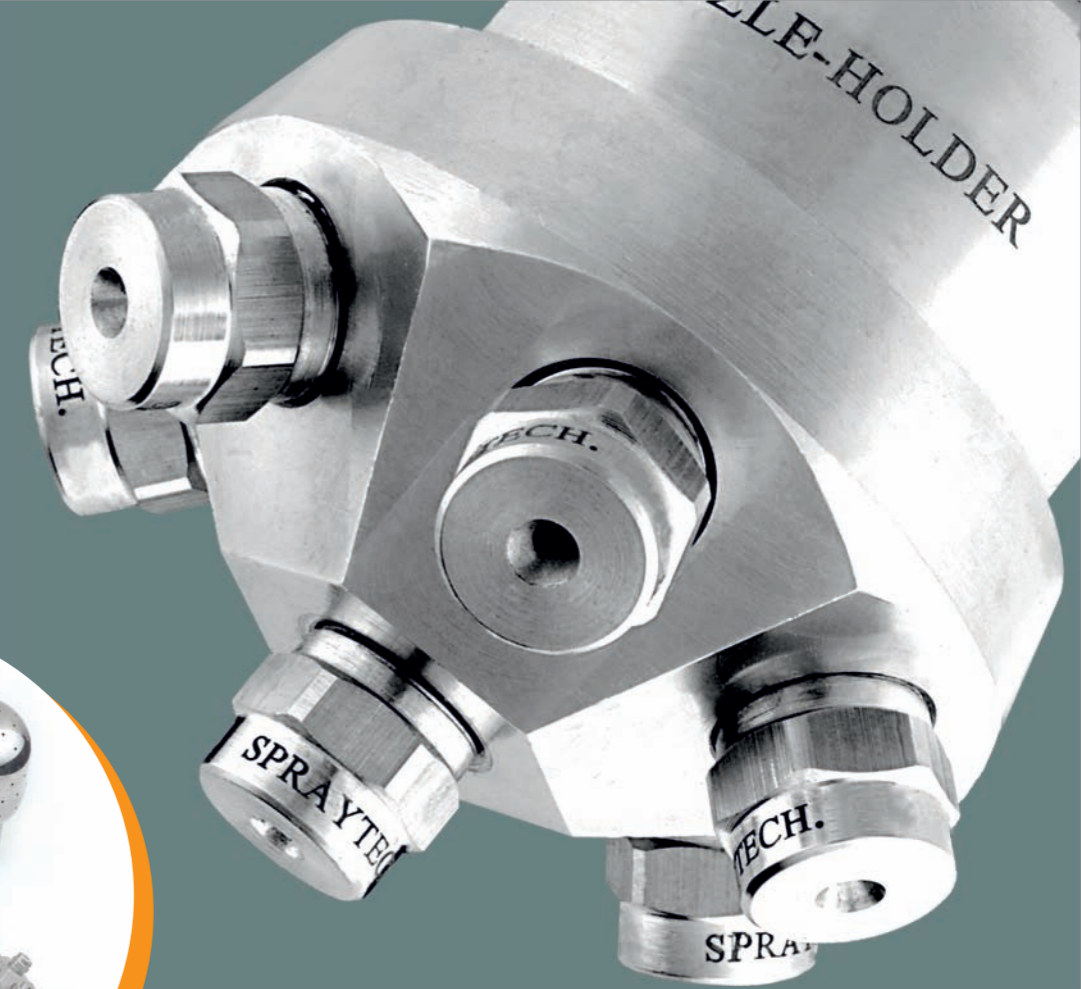

Cleaning-In-Place (CIP) Spray Nozzles

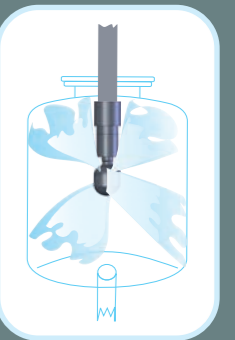

Tank washing spray nozzles selection

Overview

In this section a brief elaboration will clear the concept of spray nozzles selection for requirement and there various factors which affects and plays vital role in extent of cleaning required.

Following some factors should well studied when selecting CIP spray nozzles.

1) Extent of Cleaning

The nature of substance to be cleaned from tank should be considered like, solubility, viscosity, nature of powder / pigment material.

Based on all this factors we can decide which type of impact is necessary to flush substance from all internals of equipment.

- Rinsing : By virtue mass removal of substance and thick layers get dissolved by water or solvent
- Cleaning : After rinsing cleaning could be done with high pressure to remove rest of the residue from internal.
- High Impact Cleaning : Those substances which could not be satisfactory cleaned by means of cleaning cycle, should be treated with high pressure of cleaning fluid.
- Sanitizing : Sanitizer chemical is applied after cleaning to kill microorganisms and bacteria.
- Disinfecting : Same procedure is applied for disinfectant
- Sterilizing : It kills all kinds of bacteria.

Heat energy's role

Viscosity of fluids decreases with increasing temperature so, effective cleaning can be achieved by using hot cleaning fluids or by increasing temperature of vessel tank by means of steam jackets. By virtue of this viscosity of substances to be cleaned decrease and effective cleanliness increases

Spray Pattern

If cleaning is done manually then stationary spray nozzles are recommended to use. Ex. Flat spray nozzle, Straight jet spray nozzle, Full cone spray nozzle. For CIP self rotating spray nozzles gives droplets spray to clean the substances. For higher tank sizes tank cleaning machine is recommended as it gives cyclic control speed of rotation which provide the high impact jet cleaning with long impact distances

Obstructions due to internals

If tank is having any central agitation / mixing arrangement then multiple spray nozzle should be utilized

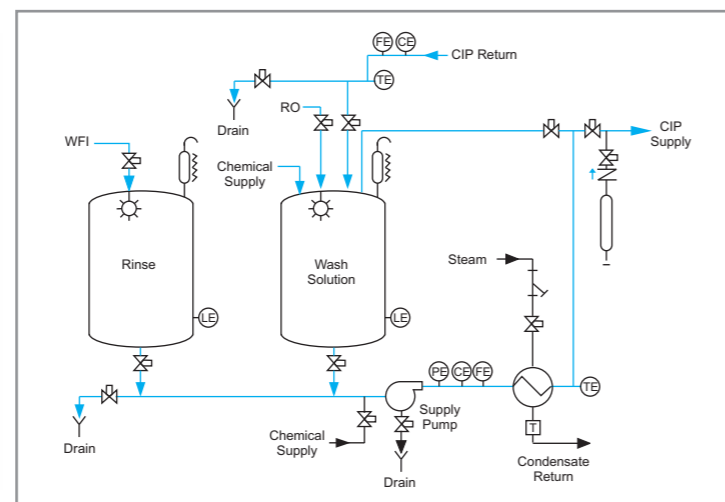

Cleaning-In-Place (CIP)

Fully or semi-automated, integrated cleaning technique that allows to clean closed or open circuits without dismantling equipments

Standard CIP sequence

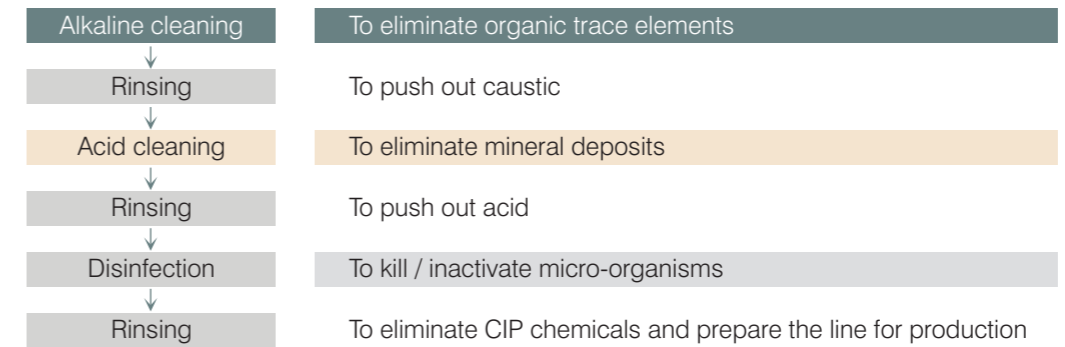

Single-use system

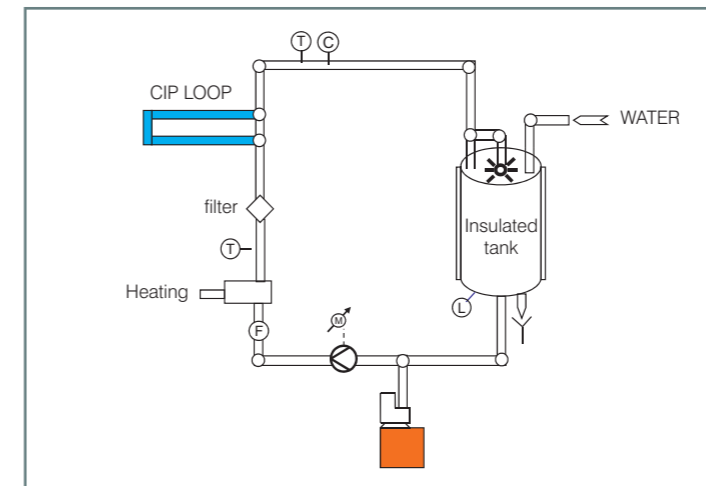

cleaning solution is used only once and discharged to drain after use single tank

Advantage

- Simple, not very costly installation
- Could be applied for:
 - Small installations (decentralized CIP system)
 - Processes where cross-contamination is a concern
- Heavy soiled equipments

Disadvantage

- High operational costs
- Environmental impact

Re-use system

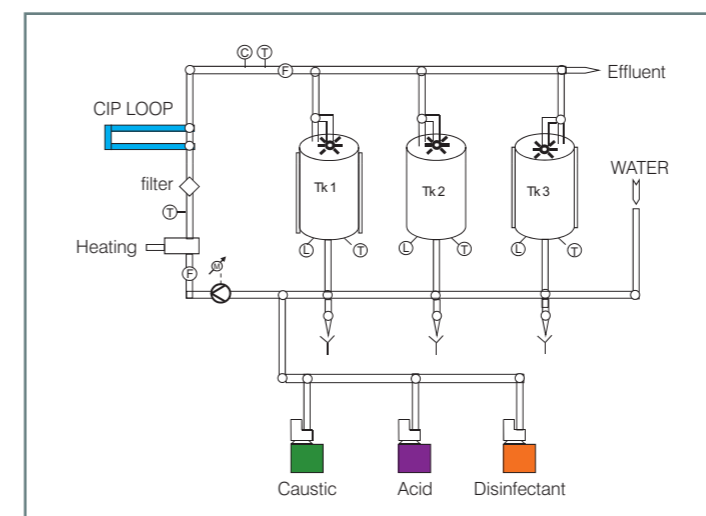

the same cleaning solution is used for a large number of cleaning operations (recover & reuse) multi-tanks

Advantage

- Lower environmental impact
- Could be applied for:
 - Large installations (centralized CIP system)

Disadvantage

- Installation can be complex and very costly
- Regular control of the cleaning power of cleaning solutions

Spraytech Product Coding System

The following description will help to explain our Part Number/ Code in relation to the "SPRAYTECH" Spray Nozzle
EXAMPLE ORDERING.

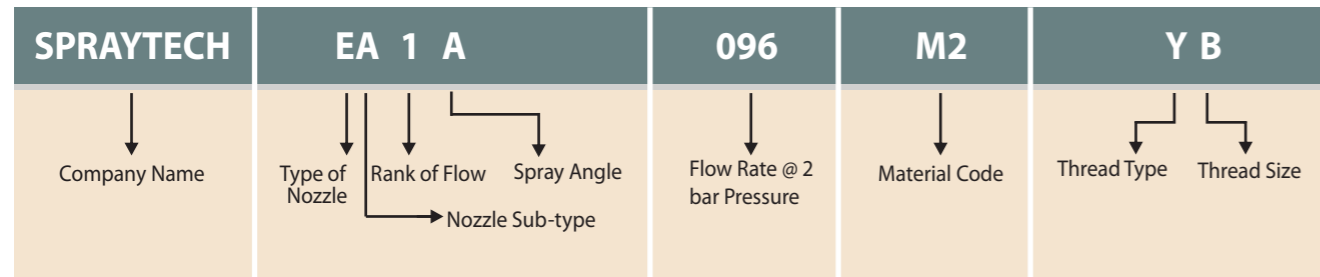

1) Codes for Spray Nozzles Type

- A Air Atomizing / Fine Atomizing Spray Nozzle
- B Hollow Cone Spray Nozzle
- C Flat Spray Nozzle
- D Full Cone Spray Nozzle
- E Tank Cleaning Spray Nozzle
- F Steel Mill Spray Nozzles
- G General Engineering & Accessories
- H Special Project

2) Nozzle Sub-type (See Table overleaf)

3) Spray Angle code

Spray Angle Code	Spray Angle	Coverage Type
A	180°	
B	180°	
C	270°	
D	270°	
E	360°	

5) Thread Type Code

X=BSPP Y= BSPT Z=NPT
Note : Special Connection on request

6) Thread Size Code

A = 1/8" B = 1/4"
C = 3/8" D = 1/2"
E = 3/4" F = 1"
G = 1 1/4" H = 1 1/2"
K = 2" L = 2 1/2"
M = 3" N = 3 1/2"
O = 4"

Note : Special Size on request

4) Material Code

M0 = M.S.
M1 = SS303/SS304
M2 = SS316/M2L=SS316L
M3 = Brass
M4 = SS410
M4-3 = SS310
M5 = Cast Iron
M6 = Aluminum
M7 = Hastelloy C / B / 2000
M8 = Titanium
M9 = Monel
P1 = PVC(Polyvinylchloride)
P2 = PP (Polypropylene)
P3 = Teflon® / PTFE (Polyterafluoroethylene)
P4 = Delrin® (Polyacetate)
P6 = PVDF (Polyvinylidene fluoride)
P7 = Polyethylene

Note : Special Material on request

Self-rotating / Stationary Tank cleaning nozzles	Series	Flow rate (Lpm) @ 2 bar	End Connection	Application / Design
	EA	8-22	1/4" 1/2" 3/8" Tri-Clover End	Cleaning of small tanks up to 1.5 m in diameter. Self - rotating. Stainless steel & Plastic versions.
	EB	18-40	1/2" Tri-Clover End	Cleaning of small tanks up to 1.5 m in diameter. Self - rotating. Stainless steel & Plastic versions.
	EC	52-225	1/2" 3/4" 1" Pin connection Tri-Clover End	Cleaning of tanks up to 3 m in diameter. Teflon Version. Self - rotating. Special version for CIP applications.
	ED	32-140	3/4" Pin connection Tri-Clover End	Cleaning of tanks up to 3 m in diameter. Self - rotating. Double bearings.
	EE	140-1100	1" 2" 3" Tri-Clover End	Efficient inside cleaning of medium size tanks (max. 5m to 9m in diameter)
	EF	40-100	3/4" 1" Tri-Clover End	Turbo cleaning spray Nozzle washing of industrial storage tanks, small barrels used in Dairy, Food & Beverage, Pharmaceutical and other process industries. (max. upto 3m in diameter)
	EG	52-100	3/8" 1/2" 3/4" 1" 1 1/4" Pin connection Tri-Clover End	For small and medium sized tanks, chemical processing, food and beverages manufacturing (maximum tank diameter 2 m to 6 m)
	EH	18-100	1/2" Tri-Clover End Pin connection	Cleaning of tanks up to 3 m in diameter. Static spray ball with sharp straight jets.
	EI	100-450	1/4" to 2" Pin connection Tri-Clover End	Cleaning of tanks up to 5 m in diameter. Static spray ball for higher flow rates.
	EJ	40-240	3/4" 1" 1 1/2" Tri-Clover End	Tank Washing nozzle assembly features a large flow capacity for cleaning tanks up to 10'(3.5m) in diameter. Flow rates ranges from 40 LPM to 240 LPM. Assembly uses 1/4" or 3/8" full cone nozzles.

* Note: All Connections are available in BSP, BSPT, NPT.

EA Self-Rotating Spray Nozzles Stainless Steel & Plastic Versions

EA

EA series nozzles are designed for cleaning process in small bore or small size of containers and available in all grade of stainless steel material and also available in plastics like PTFE along with several spray angles.

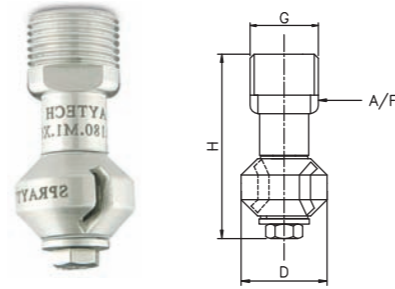

Female Connection On Request

Coverage Type	Spray Angle	MODEL NO.	CONNECTION	FLOW CAPACITY IN LPM AT DIFFERENT PRESSURE VALUES					M1/M2		P3/P4	
				Flow Capacity in GPM	Pressure [bar]					SS304/SS316	TEFLON/NYLON	
A	180°	EA2A.120.M2.XC	XC	40* psi	1	2	3	5	7	H	D	X
				B	180°	EA2B.120.M2.XC	3/8"	3.68	8.49	12	14.70	18.97
C	270°	EA2C.180.M2.XC	3/8"	3.68	8.49	12	14.70	18.97	22.45	Weight (Metals) = 30.0 gms. Approx		
D	270°	EA2D.180.M2.XC	3/8"	5.52	12.73	18	22.05	28.46	33.67	G/A DIMENSION		
E	360°	EA2E.220.M2.XC	3/8"	5.52	12.73	18	22.05	28.46	33.67	H	D	X
				6.74	15.56	22	26.94	34.79	41.16	45	21	12.8

EC Self-Rotating Spray Nozzles Stainless Steel & Plastic Versions

EC

Specially designed self rotating nozzle, rotates because of reaction principle of spraying water jets. For rinsing small and medium sized vessels for example dairy, chemical, pharmaceutical and food industries. Material of construction - corrosion - resistance PTFE. (Range available from 1/2" to 2")

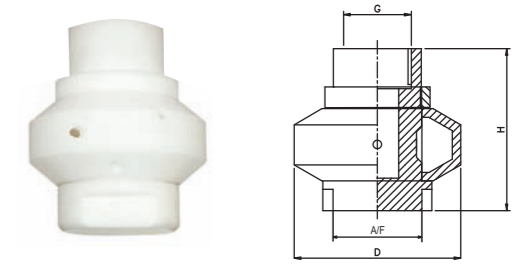

Male Connection On Request

Coverage Type	Spray Angle	MODEL NO.	CONNECTION	FLOW CAPACITY IN LPM AT DIFFERENT PRESSURE VALUES					M1/M2		P3/P4	
				Flow Capacity in GPM	Pressure [bar]					SS304/SS316	TEFLON/NYLON	
C	270°	EC2.520.M2.XE	C/D	40* psi	1	2	3	5	7	H	D	X
				D	270°	EC2.950.M2.XE	3/4"	15.94	36.77	52	63.69	82.22
E	360°	EC3.140.XE.M2	C/D/E	29.12	67.18	95	116.35	150.21	177.73	Weight (Metals) = 103 gms. Approx		
		EC3.150.M2.XF	E	42.91	98.99	140	171.46	221.36	261.92	76.2	78.5	42
		EC3.190.M2.XF	E	45.95	106.07	150	183.71	237.17	280.62	Weight (Metals) = 1015 gms. Approx		
		EC3.225.M2.XF	E	58.24	134.35	190	232.70	300.42	355.46	H	D	X
				68.97	159.10	225	275.57	355.76	420.94	G/A DIMENSION		

EB Self-Rotating Spray Nozzle Stainless Steel Versions

EB

EB series self rotating nozzles are designed as a small dimensions and opening and perform inside cleaning which is required. Typically used for cleaning like kegs, small container where the requirement is for cleaning. Diameter of nozzle is (25mm) These nozzles are available in all grade of stainless steel.

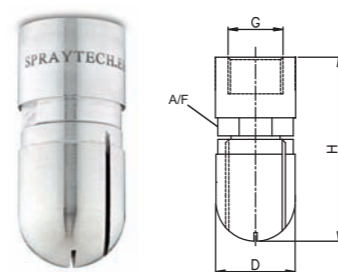

Male Connection On Request

Coverage Type	Spray Angle	MODEL NO.	CONNECTION	FLOW CAPACITY IN LPM AT DIFFERENT PRESSURE VALUES					M1/M2		P3/P4	
				Flow Capacity in GPM	Pressure [bar]					SS304/SS316	TEFLON/NYLON	
C	270°	EB2.180.M2.XD	XD	40* psi	1	2	3	5	7	H	D	X
				D	270°	EB2.220.M2.XD	1/2"	3.68	8.49	18	14.70	18.97
		EB2.280.M2.XD	C/D	3.68	8.49	22	14.70	18.97	22.45	Weight (Metals) = 95.0 gms. Approx		
		EB2.320.M2.XD	C/D	8.58	19.80	28	34.29	44.27	52.38	G/A DIMENSION		
		EB2.380.M2.XD	C/D	9.81	22.63	32	39.19	50.60	59.87	H <td>D <td>X</td> </td>	D <td>X</td>	X
				11.65	26.87	38	46.54	60.08	71.09	55	24.2	21

ED Barrel Tank Washing Spray Nozzles Stainless Steel Versions

ED

Suited for CIP systems. No motor source is needed due to the reaction force of the cleaning liquid to rotate spray head. Low pressure for cleaning and rinsing application. For rinsing small and medium sized vessels for example dairy, chemical, pharmaceutical and food industries.

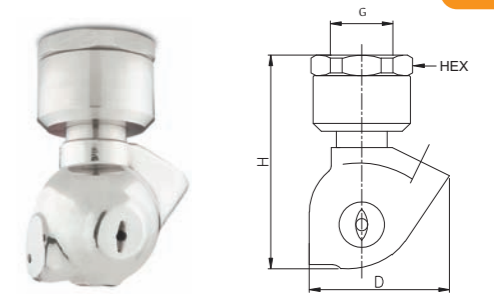

Male Connection On Request

Coverage Type	Spray Angle	MODEL NO.	CONNECTION	FLOW CAPACITY IN LPM AT DIFFERENT PRESSURE VALUES					M1		M2
				Flow Capacity in GPM	Pressure [bar]					SS304	SS316
C	270°	ED2.320.M2.XE	C	40* psi	1	2	3	5	7	H	D
				D	270°	ED2.520.M2.XE	3/4"	9.81	22.63	32	39.19
E	360°	ED2.950.M2.XE	C/D	15.94	36.77	52	63.69	82.22	97.28	Weight (Metals) = 562gms. Approx	
		ED3.140.M2.XE	C/D/E	29.12	67.18	95	116.35	150.21	177.73	100	70
				42.91	98.99	140	171.46	221.36	261.92	Weight (Metals) = 562gms. Approx	

EE Gyro Jet Tank Washing Spray Nozzles Stainless Steel Versions

EE

Self powered rotating tank cleaning nozzle used for cleaning large and medium size diameter tanks. Efficient cleaning action for medium and large size tanks. Recommended operating pressure 2 to 3 kg/cm² and also available coverage 180° (up and down), 270° (up and down) and 360°.

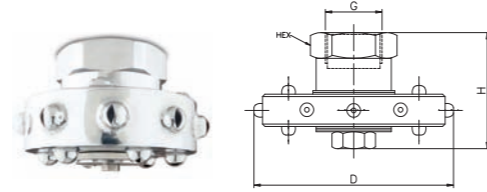

Male Connection On Request

Coverage Type	Spray Angle	MODEL NO.	FLOW CAPACITY IN LPM AT DIFFERENT PRESSURE VALUES							M1		M2			
			SPRAY ANGLE	XF CONNECTION	XK CONNECTION	XM CONNECTION	Flow Capacity in GPM	Pressure [bar]					SS304	SS316	
40*psi	1	2						3	5	7	G/A DIMENSION				
											H	D	A/F		
A	180°	EE3.140.M2.XF	A/B/C/D/E	1"			42.91	98.99	140	171.46	221.36	261.92	62.5	117	41
B	180°	EE3.250.M2.XF	A/B/C/D/E	1"			76.63	176.78	250	306.19	395.28	467.71	Weight (Metals) = 771 gms. Approx		
C	270°	EE3.275.M2.XF	A/B/C/D/E	1"			84.30	194.45	275	336.80	434.81	514.48	97	131	71
D	270°	EE3.325.M2.XK	A/B/C/D/E		2"		99.62	229.81	325	398.04	513.87	608.02	Weight (Metals) = 1930 gms. Approx		
		EE3.375.M2.XK	A/B/C/D/E		2"		114.95	265.17	375	459.28	592.93	701.56	Weight (Metals) = 1930 gms. Approx		
		EE3.625.M2.XK	A/B/C/D/E		2"		191.58	441.94	625	765.47	988.21	1169.27	Weight (Metals) = 3630 gms. Approx		
		EE3.800.M2.XM	A/B/C/D/E			3"	245.23	565.69	800	979.80	1264.91	1496.66	116.5	194	100
		EE3.950.XM.M2	A/B/C/D/E			3"	291.21	671.75	950	1163.51	1502.08	1777.29	Weight (Metals) = 3630 gms. Approx		
E	360°	EE4.1100.XM.M2	A/B/C/D/E			3"	337.19	777.82	1100	1347.22	1739.25	2057.91	Weight (Metals) = 3630 gms. Approx		

EF Turbo Cleaning Spray Nozzles Stainless Steel Versions

EF

The turbo nozzles are generally used for washing of industrial storage tanks small barrels and used in the dairy, chemical, pharmaceutical, food industries and process industries. The rotating Disc dispense an instant powerful dense spray to all the interior surface of the vessels. Spray coverage 180° up and down 360°.

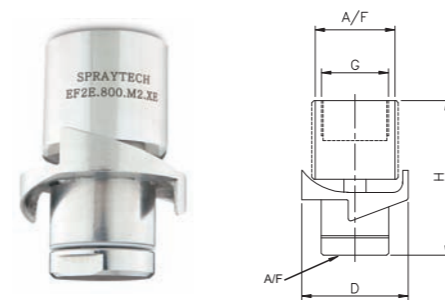

Male Connection On Request

Coverage Type	Spray Angle	MODEL NO.	FLOW CAPACITY IN LPM AT DIFFERENT PRESSURE VALUES							M1/M2		P3/P4			
			SPRAY ANGLE	XE CONNECTION	XF CONNECTION	Flow Capacity in GPM	Pressure [bar]					SS304	SS316	TEFLON/NYLON	
40*psi	1	2					3	5	7	G/A DIMENSION					
											H	D	A/F		
A	180°	EF2.400.M2.XE	A/B/E	3/4"			12.26	28.28	40.00	48.99	63.25	74.83	74	51	38
B	180°	EF2.520.M2.XE	A/B/E	3/4"			15.94	36.77	52.00	63.69	82.22	97.28	Weight (Metals)= 460gms. Approx		
		EF2.800.M2.XF	A/B/E		1"		24.52	56.57	80.00	97.98	126.49	149.67	74	51	38
E	360°	EF3.100.M2.XF	A/B/E		1"		30.65	70.71	100.0	122.47	158.11	187.08	Weight (Metals)= 460gms. Approx		

EG Slotted Spray Ball Stainless Steel Versions

EG

EG Series Slotted spray ball series are available with different connection design that it is a female thread and clip-on connection as standard. Weld-on or tri-clamp connection on request. The simple design high quality construction and having a good efficiency and applicable for general purpose application and it is available in coverage of 270° up and down and 360°.

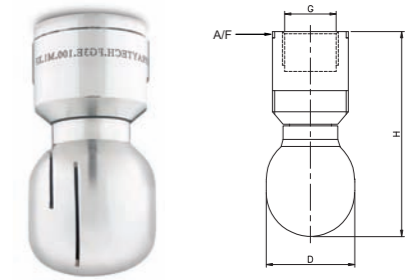

Male Connection On Request

Coverage Type	Spray Angle	MODEL NO.	FLOW CAPACITY IN LPM AT DIFFERENT PRESSURE VALUES							M1		M2		
			SPRAY ANGLE	CONNECTION	Flow Capacity in GPM	Pressure [bar]					SS 304	SS 316		
40*psi	1	2				3	5	7	G/A Dimension					
											H	D		
C	270°	EG2.520.M2.XD	C/D/E	1/2"			25.79	15.55	22.00	26.94	34.78	41.15	77	33
D	270°	EG2.520.M2.XE	C/D/E		3/4"		15.94	36.77	52.00	63.69	82.22	97.28	97.4	41
		EG2.800.M2.XF	C/D/E			1"	24.52	56.57	80.00	97.98	126.49	149.67	Weight (Metals)= 361 gms. Approx	
E	360°	EG3.100.M2.XF	C/D/E			1"	30.65	70.71	100.0	122.47	158.11	187.08	104	47.5

EH Static Spray Ball Stainless Steel & Plastic Versions

EH

EH Series Static Spray Ball has very compact design that provides straight jets for high impact rinsing of small drums or container up to ø 1.5m. Also it can be used with saturated steam. Spray coverage is available from 120° to 270°.

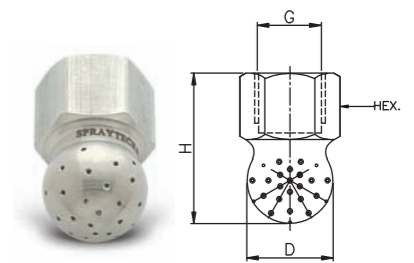

Male Connection On Request

Coverage Type	Spray Angle	MODEL NO.	FLOW CAPACITY IN LPM AT DIFFERENT PRESSURE VALUES							M1/M2		P3/P4			
			SPRAY ANGLE	XD CONNECTION	Flow Capacity in GPM	Pressure [bar]					SS304/SS316	TEFLON/NYLON			
40*psi	1	2				3	5	7	G/A DIMENSION						
											H	D	A/F		
F	240°	EH2.180.M2.XD	F	1/2"			3.68	8.49	18.00	14.70	18.97	22.45	45.3	26	27
		EH2.280.M2.XD	F	1/2"			8.58	19.80	28.00	34.29	44.27	52.38	Weight (Metals)= 57 gms. Approx		
		EH2.520.M2.XD	F	1/2"			15.94	36.77	52.00	63.69	82.22	97.28	Weight (Metals)= 57 gms. Approx		
		EH2.800.M2.XD	F	1/2"			24.52	56.57	80.00	97.98	126.49	149.67	Weight (Metals)= 57 gms. Approx		
		EH3.100.M2.XD	F	1/2"			30.65	70.71	100.0	122.47	158.11	187.08	45.3	26	27

EI Static Spray Ball Stainless Steel & Plastic Versions

EI

Static Spray balls are simple and efficient devices for cleaning and rinsing small size tanks. Usually operated at low pressure and can achieve limited impact action on the tank wall. It is a stationary design with self-cleaning retaining pin inlet connection as well as tube inlet connection. It's widely used in food processing tank cleaning, pharmaceutical tank cleaning and chemical tanks.

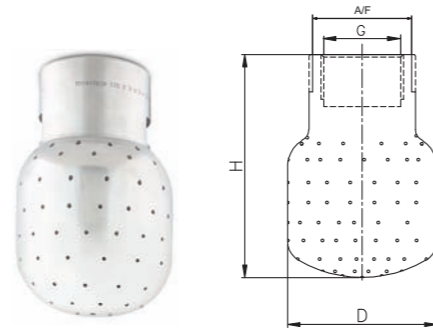

Male Connection On Request

Coverage Type	Spray Angle	MODEL NO.								FLOW CAPACITY IN LPM AT DIFFERENT PRESSURE VALUES					M1/M2	P3/P4			
		SPRAY ANGLE	XE	XF	XG	XH	XK	Flow Capacity in GPM	Pressure [bar]					SS 304/SS 316	TEFLON/NYLON				
40*psi	1								2	3	5	7	G/A DIMENSION						
A	180°																		
E	360°	EI3.100.M2.XE	A/B/E	3/4"															
A	180°	EI3.140.M2.XF	A/B/E		1"														
B	180°	EI3.190.M2.XG	A/B/E		1"	1 1/4"													
		EI3.250.M2.XH	A/B/E			1 1/4"	1 1/2"												
		EI3.325.M2.XH	A/B/E				1 1/2"												
		EI3.450.M2.XK	A/B/E					2"											



Flat Spray Full Cone Hollow Cone Spray Nozzles

Application

- Absorption
- Chemical process engineering
- Chlorine precipitation
- Cleaning
- Cooling
- Desuperheating
- Dust control
- Fire protection
- Foam control
- Gas treatment
- Spraying onto mats in air
- Washers
- Spraying over packings
- Surface spraying
- Water treatment and many others...



EJ Fixed Tank Washing Spray Nozzles Stainless Steel & Plastic Versions

EJ

Suitable for washing of thick kind of materials. Having multiple spray tips on periphery which can provide upto 360° of spray coverage. Rigid construction. M.O.C SS316, SS304.

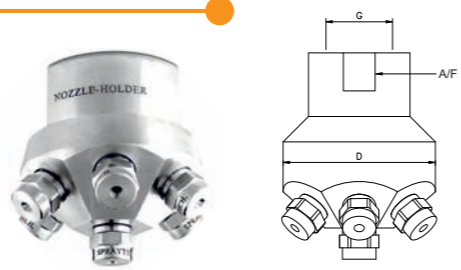

Male Connection On Request

Coverage Type	Spray Angle	MODEL NO.								FLOW CAPACITY IN LPM AT DIFFERENT PRESSURE VALUES					M1/M2	P3/P4		
		SPRAY ANGLE	XH	Flow Capacity in GPM	Pressure [bar]					SS 304/SS 316	TEFLON/NYLON							
40*psi	1				2	3	5	7	G/A DIMENSION									
A	180°																	
E	360°	EJ3.100.XH.M2	A/B/E	1 1/2"	30.65	70.71	100	122.47	158.11	187.08	121	127						
		EJ3.140.XH.M2	A/B/E	1 1/2"	42.91	98.99	140	171.46	221.36	261.92	Weight (Metals)=							
		EJ3.190.XH.M2	A/B/E	1 1/2"	58.24	134.35	190	232.70	300.42	355.46	1.7kg Approx							



BK Series Hollow Cone Spray Nozzles

Extremely fine fog hollow cone spray nozzle.

Applications:

- Disinfection
- Humidification of air
- Spraying over germinating boxes
- Product humidification
- Humidification of textiles
- Spraying of oil
- Absorption

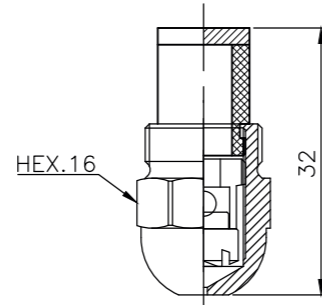

BK

60° SPRAY ANGLE	Type		ORIFICE SIZE [mm]	FLOW CAPACITY IN LPM AT DIFFERENT PRESSURE VALUES						Spray diameter D at p = 2 bar	
	End Conn.	Mat.		Pressure [bar]						H= 100 mm	H= 200 mm
			BRASS / M3	SS 304 / M1	SS 316 / M2	2.0	3.0	5.0	7.0		
			.10	-	-	.013	.015	.018	.025		
			.15	-	-	.019	.023	.027	.039		
			.20	-	-	.027	.033	.039	.057		
			.25	-	-	.040	.047	.057	.080		
			.35	-	.048	.062	.073	.088	.124		
			.40	-	.063	.082	.097	.116	.164		
			.45	-	.080	.103	.122	.146	.206		
90° SPRAY ANGLE											
			.35	-	.048	.062	.073	.088	.124		
			.40	-	.063	.082	.097	.116	.164		
			.45	-	.080	.103	.122	.146	.206		
			.50	-	.101	.130	.154	.184	.260		
			.60	.107	.131	.168	.199	.238	.336		
			.70	.166	.202	.261	.310	.370	.522		
			.90	.262	.320	.390	.460	.550	.770		

Air Conveyor

Air Conveyor is available in a number of styles, materials and sizes. Each has a large, smooth, straight bore that allows as much material to pass through as possible. Infinite control of the flow rate through the Air conveyor can be controlled by a pressure regulator. Kits include a pressure regulator that is sized properly for flow.

The actual conveying rate is affected by the size, mass and geometry of the part to be conveyed along with the length, lift and number of bends in the hose, tube or pipe. These variables make it difficult to determine the exact conveying rate for any product. However, the application engineering can assist you by comparing the material you want to convey with something that has already been tested.

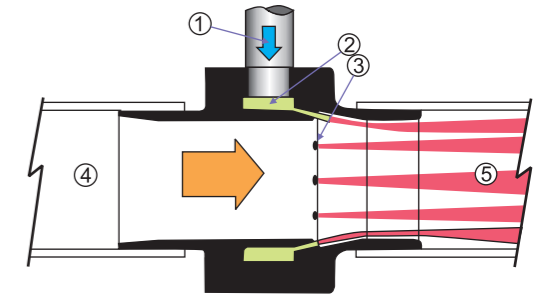

Compressed air flow through the inlet

- (1) into an annular plenum chamber
- (2) It is then injected into the throat through directed nozzles
- (3) These jets of air create a vacuum at the intake
- (4) which draws material in and accelerates it through the unit
- (5) for conveying over long vertical or horizontal distances.

Air Conveyor Performance

80 PSIG (5.5 BAR)	Air Consumption		Vacuum	
	Model	SCFM	SLPM	H2O
2710	10.7	303	-72	-18
4214	14.7	416	-42	-11
4225	25.9	733	-42	-11
3633	33	934	-36.8	-9
2845	45	1274	-28.5	-7
2358	58.5	1656	-23.5	-6
1468	68.5	1939	-14.7	-4
1395	95	2690	-13.6	-3.4
1012	128	3625	-10.5	-2.6

Applications
• Hopper loading
• Fiber tensioning
• Material conveying
• Water/trim removal
• Chip removal
• Part transfer
• Filling operations

Air Conveyor Comparison		
Material Type	Temperature Rating	Corrosion Resistance
Aluminum	275°F (135°C)	Fair
Stainless Steel (Type 303)	400°F (204°C)	Good
Stainless Steel (Type 316)	400°F (204°C)	Excellent
High Temperature Stainless Steel (Type 303)	900°F (482°C)	Good

Spray Coverage Table

This table lists the theoretical coverage of spray patterns as calculated from the included spray and the distance from the nozzle orifice. These values are based on the assumption that the spray angle remains same throughout entire spray distance. In actual practice, the tabulated spray angle does not hold for long spray distance.

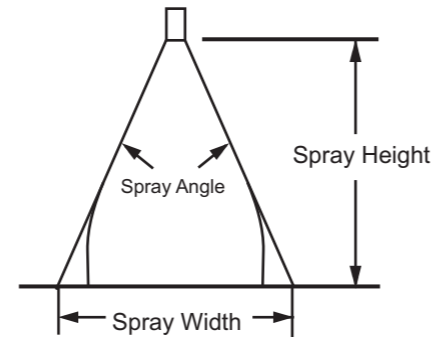

Theoretical spray Width (in mm) at various height from nozzle tip

Spray Angle	50	100	150	200	250	300	400	500	600	700	800	1000
5°	4	9	13	18	22	26	35	44	52	61	70	87
10°	9	18	26	35	44	53	70	88	105	123	140	175
15°	13	26	40	53	66	79	105	132	158	184	211	263
20°	18	35	53	71	88	106	141	176	212	247	282	353
25°	22	44	67	89	111	133	177	222	266	310	355	443
30°	27	54	80	107	134	161	214	268	322	375	429	536
35°	32	63	95	126	158	189	252	315	378	441	505	631
40°	36	73	109	146	182	218	291	364	437	510	582	728
45°	41	83	124	166	207	249	331	414	497	580	663	828
50°	47	93	140	187	233	280	373	466	560	653	746	933
55°	52	104	140	208	260	312	417	521	625	729	833	1040
60°	58	116	173	231	289	346	462	577	693	808	924	1150
65°	64	127	191	255	319	382	510	637	765	892	1020	1270
70°	70	140	210	280	350	420	560	700	840	980	1120	1400
75°	77	154	230	307	384	460	614	767	921	1070	1230	1530
80°	84	168	252	336	420	504	671	839	1010	1180	1340	1680
85°	92	183	275	367	458	550	733	916	1100	1280	1470	1830
90°	100	200	300	400	500	600	800	1000	1200	1400	1600	2000
95°	109	218	327	437	546	655	873	1090	1310	1530	1750	2180
100°	119	238	358	477	596	715	953	1190	1430	1670	1910	2380
110°	143	286	429	571	714	857	1140	1430	1710	2000	2290	2860
120°	173	346	520	693	866	1040	1390	1730	2080	2430	2771	3464
130°	215	429	643	858	1070	1290	1720	2150	2570	3002	3431	4289

Service Life

The service life of nozzle is dependent on various circumstances such as spray application, service conditions, the quality of the liquid to be sprayed. According to the material used, service life of nozzles can considerably differ.

Unit Conversion Data

MULTIPLY	By	TO OBTAIN	MULTIPLY	By	TO OBTAIN
Feet/sec	18.29	Meters/Min	Atmospheres	1.013	Bar
Feet or Water	0.0295	Atmospheres	Atmospheres	33.931	Feet of water
Feet or Water	0.884	Inches of Mercury	Atmospheres	1.0332	Kg/cm ³
Feet or Water	0.433	Psi	Atmospheres	101.3Kilo	Pascals (k Pa)
Gallons	3785	Cm ³	Atmospheres	14.696	Psi
Gallons	0.1337	Ft ³	Bar	100	KPA
Gallons	0.83257	Imperial Gallons	Bar	14.5	Psi
Gallons	3.785	Liters	Barrels (oil)	42	Galions
Gallons/min	0.06308	Liters/sec	Centimeters	0.3937	Inches
Imperial Gallons	1.2	Gallons	Centi Stokes	Sp.gravity	Centi Poise
Horsepower	1.014	Horsepower (metric)	Cm ³	0.061	in ³
Horsepower	33.000	Foot pounds/min	Cm ³	0.000264	Gallons
Horsepower	746	Watts	Cm ³	0.001	Liters
Inches	2.54	Centimeters	Ft ³	1728	in ³
Kg/cm ²	14.22	Psi	Ft ³	0.02832	M ³
Kilo Watts	1.340	Horsepower	Ft ³	7.48	Gallons
Liters	1000	Cm ³	Ft ³	28.32	Liters
Liters	0.264	Gallons	Ft ³ (water)	62.43	Pounds (Water)
Liters	0.22	Imperial Gallons	In ³	16.39	Cm ²
Liters	33.8	Ounces (Fluid)	In ³	0.00433	Gallons
Meters	3.281	Feet	In ³	0.164	Liters
Microns (μ)	0.0394	Thousandth of an inch	M ³	35.31	Ft ³
Miles/hr	44.7	Centimeters/sec	M ³	61.016	In ³
Miles/hr	1.467	Feet/sec	M ³	264.2	Gallons
Millimeres	0.0394	Inches	M ³	1000	Liters
Psi	0.068	Atmospheres	Degree (Angle)	60	Minutes
Psi	0.06895	Bar	Degree (Celsius)	(°C x 1.8) + 32	Degree (Fahrenheit)
Psi	2.307	Feet of Water	Degree (Fahrenheit)	(°F - 32)x0.56	Degree (Celsius)
Psi	0.0703	Kg/cm ²	Feet	0.3048	Meters
Psi	6.895	KPA	Feet/sec	30.48	Centimeters/sec

Trademarks

Registered Trademark Ownership

Trademark

Hastelloy®
Inconel®
Teflon®

Property of :

Haynes International, Inc.
Inco Nickel Sales, Inc.
E.I. Dupont de Nemours and Company

Trademark

Viton®
Monel®
Stellite®

Property of :

Dupont Dow Elastomers.
The International Nickel Company, Inc.
Stoody Deloro Stellite, Inc.



RMG / HSG / Binder Spray Nozzle

Customer Details

Company Name _____ Contact No. _____
Contact Person _____ E-mail _____

Equipment Details

Equipment RMG HSG Lab Model Equipment Capacity (Kg) _____
Equipment Make _____ Year of Manufacturing _____

Required Parameters for Spraytech Make RMG / HSG / Binder Spray Nozzle

Nature of Liquid _____ Liquid Viscosity _____
Liquid Density _____ Required Liquid Flow Rate or Nozzle Orifice Size _____
Spray Pattern Full Cone Hollow Cone Flat Spray No. of Heads _____
Mounting Arrangement Threaded Nozzle Spray Lance Features With Anti-Drip / Auto Shut-off
Quantity _____ Without Anti-Drip / Auto-Shut off

Please Explain in Brief About Current Method of Spraying Solution

Please Attach a GA Drawing or Sketch With Dimensions of Your RMG / HSG

Top Spray Lance / Nozzle

Customer Details

Company Name _____ Contact No. _____
 Contact Person _____ E-mail _____

Equipment Details

Equipment FBP FBE FBC FBD Shell Diameter _____
 Equipment Make _____ Equipment Capacity (kg) _____
 Existing spray system Top Spray Lance Top Spray Nozzle NONE

Existing Spray Lance / Nozzle Details

Manufacture Name _____ Model No. _____
 No. of Lance / Nozzle _____ Orifice Size _____
 No. of Heads _____ Flow Rate _____

Required Operating Parameters

Liquid Flow Rate / Nozzle Orifice Size _____ Nature of Liquid _____
 Spray Angle _____ Liquid Viscosity _____
 MOC for Lance / Nozzle _____ Liquid Density _____
 Features With Anti-Drip / Auto Shut-off Liquid Pressure _____
 Without Anti-Drip / Auto-Shut off

Required GA Dimensions

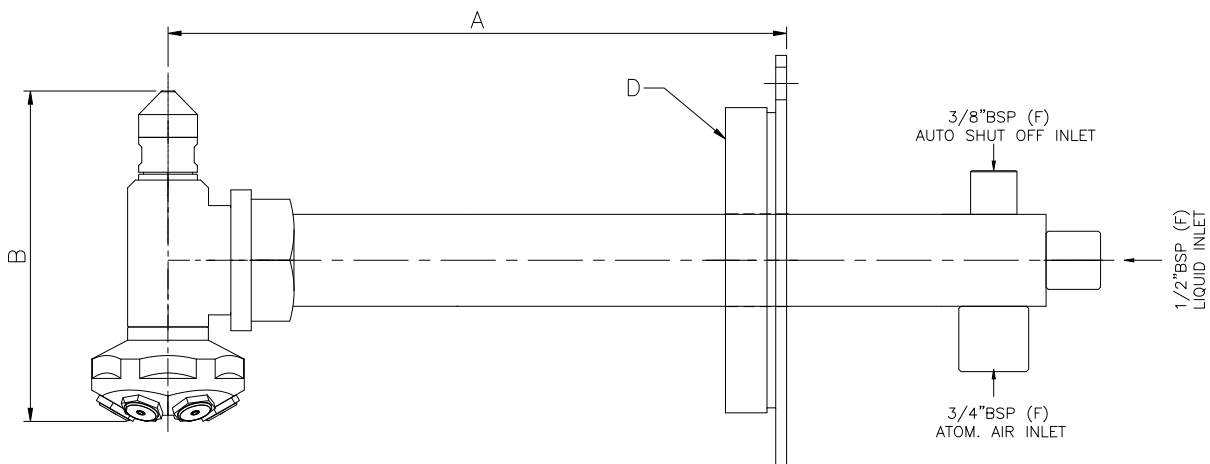

A] Length (mm) _____
 B] Length (mm) _____
 C] No. of Head _____
 D] Flange Details _____

Wurster Coating (Bottom) Spray Lance / Nozzle

Customer Details

Company Name _____ Contact No. _____
Contact Person _____ E-mail _____

Equipment Details

Equipment FBP FBE FBC FBD
Equipment Make _____
Existing spray system Bottom (Wurster) Spray Lance
 Bottom (Wurster) Spray Nozzle
Wurster Column Diameter _____
Wurster Column Height _____
Equipment Capacity (kg) _____

Existing Spray Lance / Nozzle Details

Manufacture Name _____ Model No. _____
No. of Lance / Nozzle _____ Orifice Size _____
Features With Anti-Drip / Auto Shut-off
 Without Anti-Drip / Auto-Shut off
Flow Rate _____

Required Operating Parameters

Liquid Flow Rate / Nozzle Orifice Size _____ Nature of Liquid _____
Spray Angle _____ Liquid Viscosity _____
MOC for Lance / Nozzle _____ Liquid Density _____
Features With Anti-Drip / Auto Shut-off
 Without Anti-Drip / Auto-Shut off
Liquid Pressure _____

Required GA Dimensions

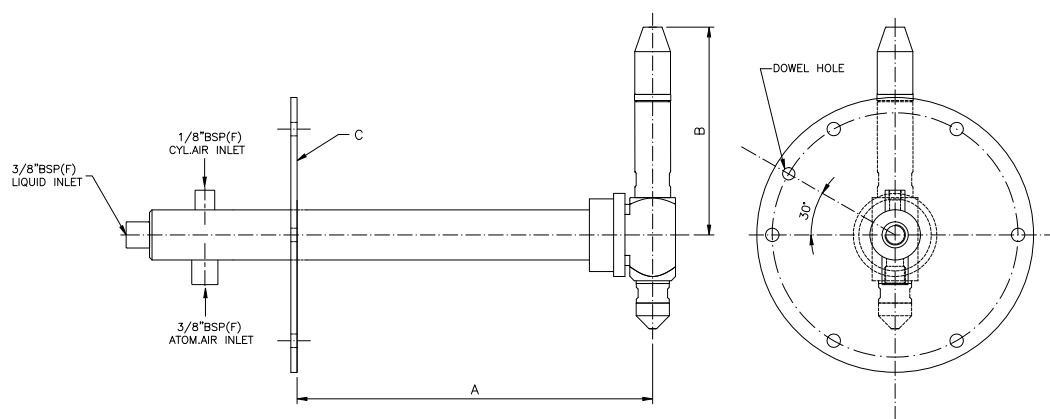

A] Length (mm) _____
B] Length (mm) _____
C] Flange Details _____

Required Quantity _____

Tablet Coating Spray Nozzle

Customer Details

Company Name _____ Contact No. _____
 Contact Person _____ E-mail _____

Equipment Details

Equipment Auto Coater Conventional Coater Lab Coater
 Equipment Make _____ Pan Size (Inch) _____
 No. of Coating Nozzle at Present in Coater _____ Existing Coating Nozzle Coating Nozzles None

Existing Coating Nozzle Details

Manufacture Name _____ Model No. _____
 Material of Construction _____ Liquid Nozzle Orifice Size _____
 Coating Nozzle Features Anti Bearding No. Connection Ports on _____
 Auto-Shut off / Anti-Drip Existing Coating Nozzle _____

Required Parameters for Spraytech Make Coating Nozzle :

Spraytech Make Coating Spray Nozzle Model RAS RB RC
 Required Liquid Nozzle Orifice Size _____ Quantity _____

Spares :

Spraytech Make Coating Nozzle Spares Air Cap Fluid Cap Needle Assembly O-Rings
 For Other Make Coating Nozzle Spares Air Cap Fluid Cap Needle Assembly
 (Please Provide Part Number and Sample)

Accessories for Coating Spray Nozzle (Please Refer Below Schematic for Selection) :

<input type="radio"/> Mounting stud	Rod size	_____	Qty. _____
<input type="radio"/> Plug	End connection	_____	Qty. _____
<input type="radio"/> Barb connector	Tube ID	_____	Qty. _____
<input type="radio"/> Nipple	End connection	_____	Qty. _____
<input type="radio"/> Push-in connector	End connection	_____	Qty. _____
<input type="radio"/> Flow regulator	End connection	_____	Qty. _____

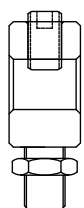

MOUNTING STUD

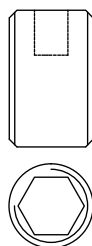

PLUG

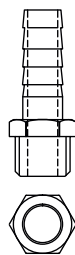

BARB CONNECTOR

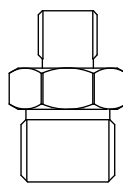

NIPPLE

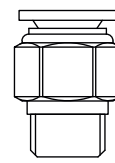

PUSH-IN CONNECTOR

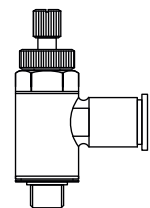

FLOW REGULATOR

Tank Washing Nozzle / CIP Nozzle / CIP Lance

Customer Details

Company Name _____ Contact No. _____
 Contact Person _____ E-mail _____

Background On Current Tank Washing System

Number of Tanks _____ Horizontal Vertical Material of Construction _____
 Diameter _____ Length _____
 Tank Opening Size _____ Drain Hole Size _____
 Current Status of Tank Washing ? New Installation Manual Cleaning Existing Spray System

If Having Existing Spray System, Please Provide The Following Details :

Manufacturer Name _____ Model No. _____
 Operating Pressure _____ Operating Flow Rate _____
 Cleaning Time _____

Product Residue :

Name/Description of Residue on Tank _____
 Residue Classification Easily Rinsed off Easily Dissolved by Cleaning Liquid
 Sticky/Stubborn Residue Hard/Dried - Crusted to Surface

Cleaning Liquid Properties :

Name of Cleaning Liquid _____ pH Level _____
 Viscosity _____ Density/Specific Gravity _____
 Flammable Corrosive Abrasive
 How Much Liquid is Available for Cleaning (Lpm) _____ How Much Pump Pressure is Available at Tank ? _____
 Is The Cleaning Liquid Re-Circulated ? Yes No
 Is The Cleaning Liquid Filtered ? Yes No If Yes, What Strainer and Mesh Size is Used ? _____

Type of Cleaning Required :

Rinsing Cleaning High Impact Cleaning
 Type of Tank Cleaning Nozzle Preferred : Stationary Self Rotating

Spray Coverage :

360° 270° Up 270° Down 180° Up 180° Down Other _____

For Tank Cleaning Lance :

- Nozzle (if Known) _____
- Flange Details _____
- Pipe Connection _____
- Pipe / Tube Size _____
- Lance Length A _____
- Lance Length B _____
- Material _____

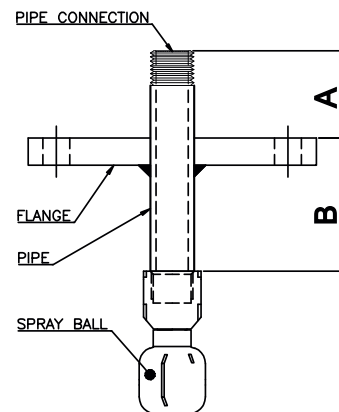



Spraytech Location Map



- Regd. Office (Thane)
- Rabale Plant (Navi Mumbai)
- Indapur Plant (Pune)

Regd. Office :
20 KMS from Mumbai International Airport



Regd. Office :

Spraytech House, Plot A-132, Road No. 23,
Spraytech Circle, Wagale Indl. Estate,
Thane (W) - 400 604. Mumbai - Maharashtra, (India)
Tel. : 91-022-2582 8929/2735/2736
Fax : 91-022-2581 2861
E-mail : sales@spraytechindia.com
sales1@spraytechindia.com

Rabale Plant :

Spraytech Systems (I) Pvt. Ltd.,
Plot No.: R-513, MIDC,
TTC Industrial Area,
Rabale, Navi Mumbai-400 701.

Indapur Plant :

Spraytech Systems (I) Pvt. Ltd.,
Plot No.: A-5,
Indapur Five Star Industrial Area
Village - Loni Devkar Balpudi,
Tal. - Indapur,
Dist. - Pune. 413103